

Hardware system for room division applications for panel weights up to 120 kg (264 lbs.).

Description

In the event of an odd number of panels, the last panel can be designed as a communicating door. A stop can be provided on top if desired. When open, the panels are at an angle of 90° to the closed partition. The panel stacks may be arranged on the right- and/or left-hand side. Within a panel stack, the panels are hinged together. Starting from the first panel (which is hinged to the frame), every second panel is suspended at its side edge. This calls for a floor guide. To fix non-guided panels, a bar bolt lock is placed at the end of panels 1, 3, 5, etc. When the partition is closed, the panels are secured into the bottom guide channel.

The first panels should be made slightly narrower in precise ratio to the other panels. The width of the first panel hinged at the rear (1) is not identical to that of the following panels.

Features of the HAWA 20-c Folding wall 120

- Hardware system for room division applications
- Max panel weight: 120 kg (264 lbs.)
- Max panel width: 1000 mm (3'3 ⁵/₈")
- Special trolley as supplementary component for fire doors
- Adjustable vertically ± 2 mm (³/₃₂")

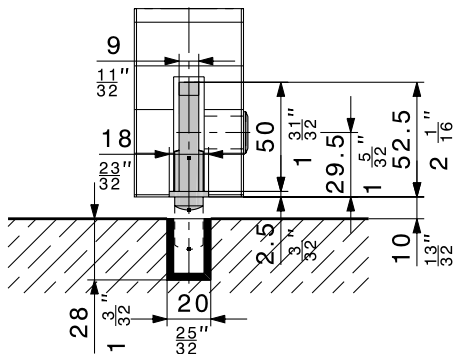
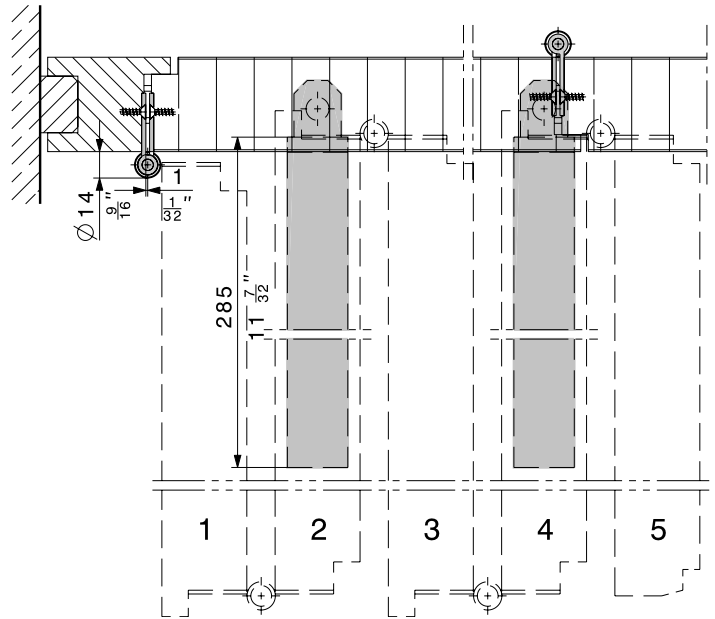
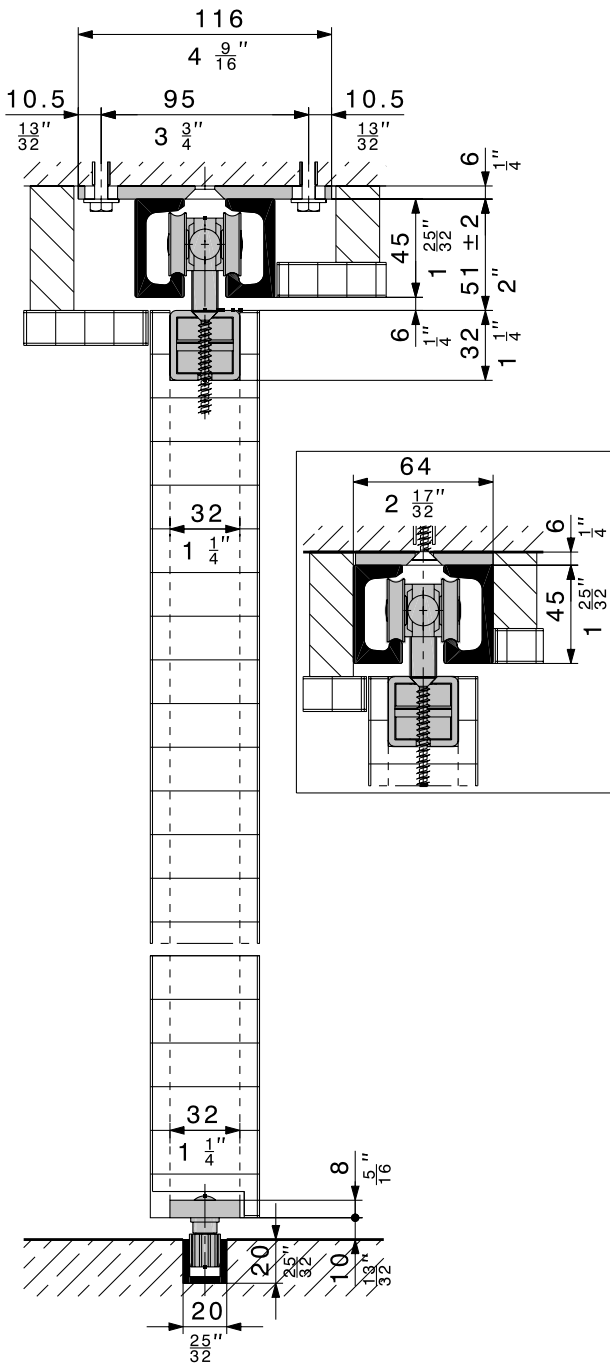



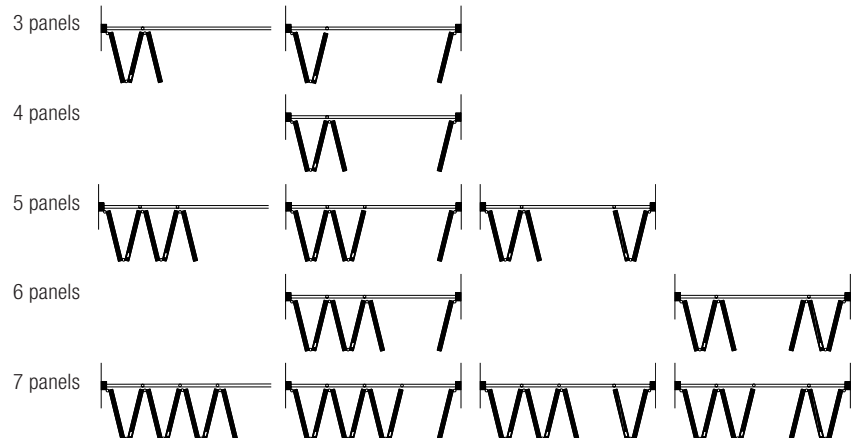

Installation examples









Subject to modification. Metric specifications are exact. Inches are approximate.

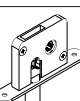

Sets without running track and bottom guide channel

		code
	Set for 3 panels	12804
	Set for 4 panels	12805
	Set for 5 panels	12806
	Set for 6 panels	12807
	Set for 7 panels	12808



Set comprising

		12804	12805	12806	12807	12808	code
	Four-wheeled trolley, M12, steel ball bearing wheels	1	1	2	2	3	10362
	Top and edge fixed bracket, with suspension plate and hanger bolt M12	1	1	2	2	3	10453
	Edge fixed bottom guide with rattle proof guide piece, 14 mm ($\frac{9}{16}$ "	1	1	2	2	3	12945
	Ball bearing hinge, steel dull nickel finish, with fixing screws	9	12	15	18	21	10652
	Deadbolt lock, 13 mm ($\frac{17}{32}$) galvanized steel	1	1	2	2	3	10726
	Slip-fit rose, brass dull nickel finish	1	1	2	2	3	13858
	Key for deadbolt lock	1	1	1	1	1	10723

Dual running tracks

Caution: Hole positions vary		mm/inch	code
	Dual running track, stainless steel, WNR 1.4301/AISI 304, with top mounting flanges	6000 (19'8 $\frac{7}{32}$ ")	18039
		cut to size	18040
	Dual running track, stainless steel, WNR 1.4301/AISI 304, with flush mounting flanges	6000 (19'8 $\frac{7}{32}$ ")	18496
		cut to size	18497

Accessories

		code
	Ball bearing hinge, burnished steel, with fixing screws	10666
	Track stop, galvanized steel, to be drilled into the track	16768







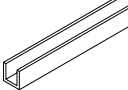

Component for fire-retarding doors

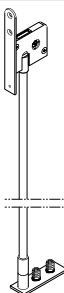
		code
	Four-wheeled trolley M12, steel, with steel ball bearing wheels	15558

Bottom guide channels

Caution: Hole positions vary		mm/inch	code
	Bottom guide channel, alu plain anodized, predrilled, 20 x 20 x 3 mm ($\frac{25}{32}$ " x $\frac{25}{32}$ " x $\frac{1}{8}$ "	6000 (19'8 $\frac{7}{32}$ ")	14414
		cut to size	14415
	Bottom guide channel, brass, predrilled, 20 x 28 x 3 mm ($\frac{25}{32}$ " x 1 $\frac{1}{8}$ " x $\frac{1}{8}$ "	6000 (19'8 $\frac{7}{32}$ ")	10245
		cut to size	10247

HAWA-Bar bolt lock

		code
	Bar bolt lock Backset 42,5 mm (1 $\frac{11}{16}$ ") Socket square/hexagonal, 7/8 mm Total lift of push rod: 18 mm ($\frac{23}{16}$ ") Operation height: 960 mm (3'11 $\frac{13}{16}$ ") complete The bar bolt lock can be operated from the door surface with a square/hexagonal key.	19592
	Thumbturn, chromium finish, for panel thickness 35 to 40 mm (1 $\frac{3}{8}$ " to 1 $\frac{59}{64}$ ")	13789
	Thumbturn, chromium finish, for panel thickness 41 to 57 mm (1 $\frac{5}{8}$ " to 2 $\frac{1}{4}$ ")	19806
	Key for deadbolt lock	10723
	Slip-fit rose, brass dull nickel finish	13858
	Floor-mounted sleeve with oblong hole and chromium plated brass spring cover	13787
	Rosette for floor-mounted sleeve 13787	17326
	Strike plate, chromium-plated steel	13130

Quantity of hinges required

panel height	pieces
up to 2500 mm (8'2 $\frac{7}{16}$ ")	3
2501–3200 mm (8'2 $\frac{55}{32}$ "–10'6")	4
3201–4000 mm (10'6 $\frac{1}{32}$ "–13'1 $\frac{1}{2}$ ")	5

Order specifications

We require the following details in order to prepare a quote and version for you:

- Sketch of the situation
- Clearance dimensions
- Quantity of panels
- Width and height of panels
- Weight of one panel
- Panel thickness
- Quantity of supplementary hinges

Planning/installation

For planning and execution please use the installation drawing code 12398. (→ www.hawa.ch → HAWA-Productfinder)